

# iW3610 Product Brief

AC/DC Digital Power Controller for Dimmable LED Drivers

**iWatt**

## 1.0 Features

- Isolated ac-dc offline 100 V<sub>ac</sub> / 230 V<sub>ac</sub>
- Line frequency ranges from 47 Hz to 64 Hz
- Intelligent wall dimmer detection
  - » Leading-edge
  - » Trailing-edge
  - » No-dimmer detected
  - » Unsupported dimmer
- Hybrid dimming scheme
- Wide dimming range from 2% up to 100%
- No visible flicker
- Resonant control to achieve high efficiency, 85% without dimmer
- Meets Harmonic Requirement, high power factor (0.9) without dimmer
- Temperature control to adjust LED brightness
- Small size design
  - » small size input bulk capacitor
  - » small size output capacitor
  - » smallest transformer
- Primary-side sensing eliminates the need for opto-isolator feedback and simplifies design
- Tight LED current regulation
- Fast start-up, typically 10 μA start-up current
- Up to 45 W
- Precise LED current control
- Multiple protection features:
  - » LED open protection
  - » Single-fault protection
  - » Over-current protection
  - » LED short circuit protection
  - » Current sense resistor short protection
  - » Over-temperature protection

## 2.0 Description

The iW3610 is a high performance AC/DC offline power supply controller for dimmable LED luminaires, which uses advanced digital control technology to detect the dimmer type and phase. The dimmer conduction phase controls the LED brightness. The LED brightness is modulated by PWM-dimming. The dimming frequency is selectable via product options. iW3610's unique digital control technology eliminates visible flicker.

iW3610 can operate with all dimmer schemes including: leading-edge dimmer, trailing-edge dimmer, as well as other dimmer configurations such as R-type, R-C type or R-L type. When a dimmer is not present, the controller can automatically detect that there is no dimmer.

iW3610 operates in quasi-resonant mode to provide high efficiency. Also the iW3610 provides a number of key built-in features. Since the iW3610 uses iWatt's advanced primary-side sensing technology, it achieves excellent line and load regulation without secondary feedback circuitry. In addition, iW3610's pulse-by-pulse waveform analysis allows for accurate LED current regulation. The iW3610 also maintains stability over all operating conditions without the need for loop compensation components. Therefore, the iW3610 minimizes external component count, simplifies EMI design and lowers overall bill of materials cost.

## 3.0 Applications

- Dimmable LED luminaires

# iW3610 Product Brief

AC/DC Digital Power Controller for Dimmable LED Drivers

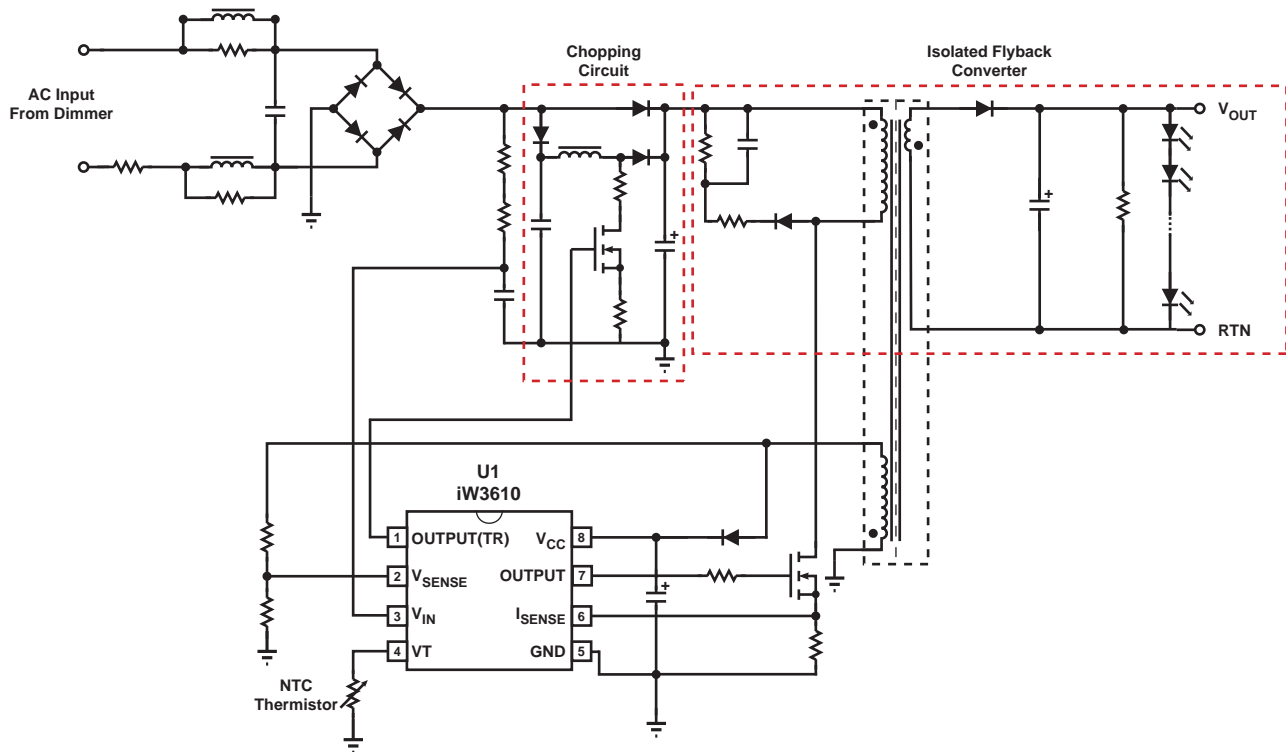
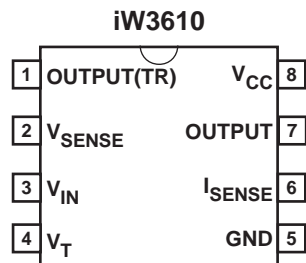

Figure 3.1 : Typical Application Circuit

## 4.0 Pinout Description



Pin #	Name	Type	Pin Description
1	OUTPUT(TR)	Output	Gate drive for chopping MOSFET switch.
2	$V_{SENSE}$	Analog Input	Auxiliary voltage sense (used for primary side regulation).
3	$V_{IN}$	Analog Input	Rectified AC line average voltage sense.
4	$V_T$	Analog Input	External shutdown control.
5	GND	Ground	Ground.
6	$I_{SENSE}$	Analog Input	Primary current sense (used for cycle-by-cycle peak current control and limit).
7	OUTPUT	Output	Gate drive for external main MOSFET switch.
8	$V_{CC}$	Power Input	Power supply for control logic and voltage sense for power-on reset circuitry.

# iW3610 Product Brief

AC/DC Digital Power Controller for Dimmable LED Drivers



## 5.0 Absolute Maximum Ratings

Absolute maximum ratings are the parameter values or ranges which can cause permanent damage if exceeded. For maximum safe operating conditions, refer to Electrical Characteristics in Section 6.0.

Parameter	Symbol	Value	Units
DC supply voltage range (pin 8, $I_{CC} = 20\text{mA max}$ )	$V_{CC}$	-0.3 to 18	V
DC supply current at $V_{CC}$ pin	$I_{CC}$	20	mA
Output (pin 7)		-0.3 to 18	V
Output(TR) (pin 1)		-0.3 to 18	V
$V_{SENSE}$ input (pin 2, $I_{Vsense} \leq 10\text{ mA}$ )		-0.7 to 4.0	V
$V_{IN}$ input (pin 3)		-0.3 to 18	V
$I_{SENSE}$ input (pin 6)		-0.3 to 4.0	V
$V_T$ input (pin 4)		-0.3 to 4.0	V
Power dissipation at $T_A \leq 25^\circ\text{C}$	$P_D$	526	mW
Maximum junction temperature	$T_{J\text{MAX}}$	125	$^\circ\text{C}$
Storage temperature	$T_{STG}$	-65 to 150	$^\circ\text{C}$
Lead temperature during IR reflow for $\leq 15$ seconds	$T_{LEAD}$	260	$^\circ\text{C}$
Thermal Resistance Junction-to-PCB Board Surface Temperature	$\psi_{JB}$ (Note 1)	70	$^\circ\text{C/W}$
ESD rating per JEDEC JESD22-A114		2,000	V
Latch-Up test per JEDEC 78		$\pm 100$	mA

### Notes:

Note 1.  $\psi_{JB}$  [Psi Junction to Board] provides an estimation of the die junction temperature relative to the PCB [Board] surface temperature. This data is measured at the ground pin (pin 5) without using any thermal adhesives. See iW3610 Datasheet for more information.

# iW3610 Product Brief

AC/DC Digital Power Controller for Dimmable LED Drivers



## 6.0 Physical Dimensions

### 8-Lead Small Outline (SOIC) Package

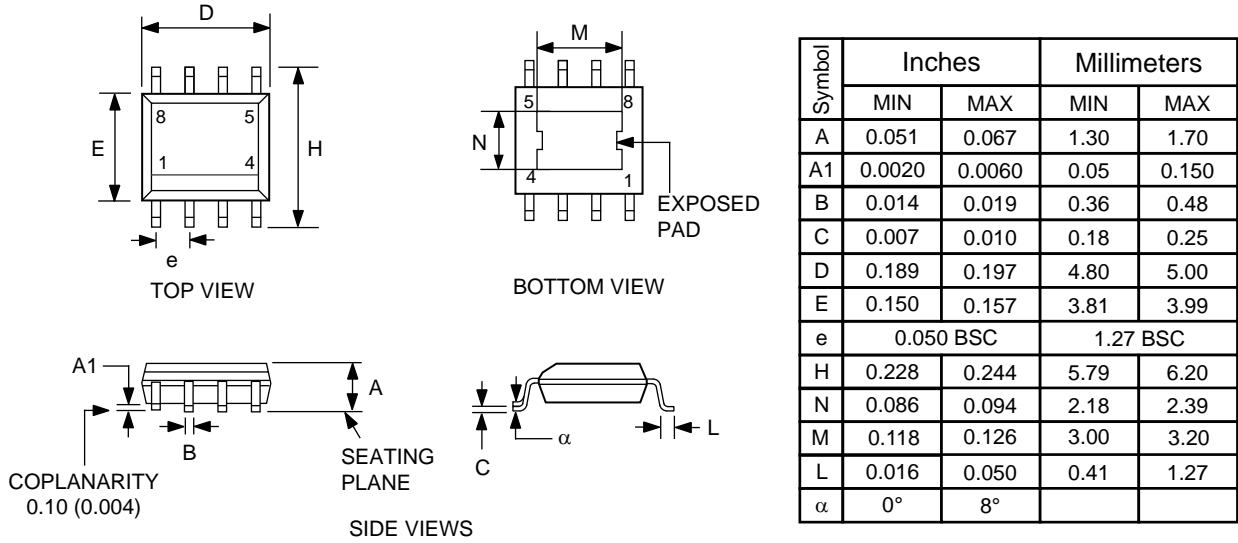

Figure 6.1 : Physical dimensions, 8-lead SOIC package

Compliant to JEDEC Standard MS12F

Controlling dimensions are in inches; millimeter dimensions are for reference only

This product is RoHS compliant and Halide free.

Soldering Temperature Resistance:

[a] Package is IPC/JEDEC Std 020D Moisture Sensitivity Level 1

[b] Package exceeds JEDEC Std No. 22-A111 for Solder Immersion Resistance; package can withstand 10 s immersion < 270°C

Dimension D does not include mold flash, protrusions or gate burrs. Mold flash, protrusions or gate burrs shall not exceed 0.15 mm per end. Dimension E does not include interlead flash or protrusion. Interlead flash or protrusion shall not exceed 0.25 mm per side.

The package top may be smaller than the package bottom. Dimensions D and E are determined at the outermost extremes of the plastic body exclusive of mold flash, tie bar burrs, gate burrs and interlead flash, but including any mismatch between the top and bottom of the plastic body.

## 7.0 Ordering Information

Part Number	Options	Package	Description
iW3610-00	Optimized for 85 V <sub>AC</sub> to 135 V <sub>AC</sub> Input	SOIC-8 (exposed pad)	Tape & Reel <sup>1</sup>
iW3610-01	Optimized for 185 V <sub>AC</sub> to 265 V <sub>AC</sub> Input	SOIC-8 (exposed pad)	Tape & Reel <sup>1</sup>

Note 1: Tape & Reel packing quantity is 2,500/reel.

# iW3610 Product Brief

AC/DC Digital Power Controller for Dimmable LED Drivers



## About iWatt

iWatt Inc. is a fabless semiconductor company that develops intelligent power management ICs for computer, communication, and consumer markets. The company's patented *pulseTrain*<sup>™</sup> technology, the industry's first truly digital approach to power system regulation, is revolutionizing power supply design.

### Trademark Information

© 2008 iWatt, Inc. All rights reserved. iWatt, the iW light bulb, *EZ-EMI* and *pulseTrain* are trademarks of iWatt, Inc. All other trademarks and registered trademarks are the property of their respective companies.

### Contact Information

**Web:** <http://www.iwatt.com>

**E-mail:** [info@iwatt.com](mailto:info@iwatt.com)

**Phone:** 408-374-4200

**Fax:** 408-341-0455

**iWatt Inc.**

101 Albright Way

Los Gatos CA 95032-1827

### Disclaimer

iWatt reserves the right to make changes to its products and to discontinue products without notice. The applications information, schematic diagrams, and other reference information included herein is provided as a design aid only and are therefore provided as-is. iWatt makes no warranties with respect to this information and disclaims any implied warranties of merchantability or non-infringement of third-party intellectual property rights.

Certain applications using semiconductor products may involve potential risks of death, personal injury, or severe property or environmental damage ("Critical Applications").

IWATT SEMICONDUCTOR PRODUCTS ARE NOT DESIGNED, INTENDED, AUTHORIZED, OR WARRANTED TO BE SUITABLE FOR USE IN LIFE-SUPPORT APPLICATIONS, DEVICES OR SYSTEMS, OR OTHER CRITICAL APPLICATIONS.

Inclusion of iWatt products in critical applications is understood to be fully at the risk of the customer. Questions concerning potential risk applications should be directed to iWatt, Inc.

iWatt semiconductors are typically used in power supplies in which high voltages are present during operation. High-voltage safety precautions should be observed in design and operation to minimize the chance of injury.