



What is Digital Power?

iWatt Inc
101 Albright Way
Los Gatos, CA 95032
USA

- 1.0. Introduction2
- 2.0. Power Feedback and Control2
- 3.0. Benefits of Digital Power.....3

1.0 Introduction

Digital power has come out of the realm of R&D lab and into the main stream. In recent years digital power has made great strides, offering performance improvements previously not attainable.

In industry, the term “digital power” is often loosely defined with respect to power supplies. Sometimes the term “digital power supply” refers to merely a power supply which is digital, otherwise known as a switching power supply. This type of supply may utilize either digital or analog methods to control the on/off time of the power MOSFET.

Also, analog power supply controllers may make use of digital circuitry for power supply sequencing and tracking, voltage margining, as well as I²C implementations or reading back fault conditions such as input/output under voltage and over voltage, output short circuit, etc. The use of such digital circuits does not make an analog power IC digital power.

The digital power this paper refers to is when the feedback and control loop in a power supply is implemented using digital algorithms. In this paper we will first explore the difference between analog and digital power supplies, followed by the benefits derived from digital power supplies.

2.0 Power Feedback and Control

How the power supply IC's feedback and control loop is implemented determines whether the power supply IC is an analog or a digital power IC. A power supply converts a fixed or variable input voltage or current to a fixed output voltage or current. For example, to maintain a fixed output voltage (V_{OUT}), a portion of the output voltage is fed back to the control loop and compared with a set point reference; the difference in these two parameters is called the error signal (see Figure 2.1). If any change in the output condition, such as a step change in the output current, causes V_{OUT} to deviate from its desired output voltage setting then the error signal causes the control loop to either increase or decrease V_{OUT} until it reaches the pre-set output voltage. The IC accomplishes this by controlling the amount of time the power transistor is on or off. If V_{OUT} is low then the power transistor stays on longer until V_{OUT} reaches the pre-set output voltage; conversely if V_{OUT} is high then the power transistor is off longer until the output is discharged and V_{OUT} reaches the pre-set output voltage. The modulation of the driver's pulse width as described above is called Pulse Width Modulation (PWM). In an analog power supply, the feedback and control loop is analog as shown in Figure 2.1.

In the case of a digital power supply, the feedback and control loop is digital (Figure 2.2). The feedback signal is first converted to a digital number which is then compared to the set point and a digital number is generated which corresponds to the error term. This error term is then fed into the digital equivalent of a loop filter. It is the numeric equivalent of a Proportional-Integral-Derivative (PID) filter (see Figure 2.3). The three terms, P (proportional), I (integral), and D (derivative) determine the required loop response. The digital output of the PID filter is further converted to the “ON” time for the power transistor. The result of this calculation is then measured out by a counter, thus controlling the power delivered to the output capacitor to bring V_{OUT} back to its pre-set voltage after any perturbation. The operation of a PID filter is described below:

1. The P path is the gain of the error signal. If the gain is large, V_{OUT} will return to its pre-set value quickly.
2. The D path is the rate-of-change of the error signal. As the output voltage gets closer to the pre-set output voltage, the gain is reduced; thus parameter D reduces voltage over shoot.
3. The I path is the time integral of past error signals and it allows the maintenance of constant output of the loop filter in order to maintain the desired output voltage even though the error signal is zero.

In this way the P and D parameters work together with the I term to accomplish loop stability while still maintaining zero offset error.

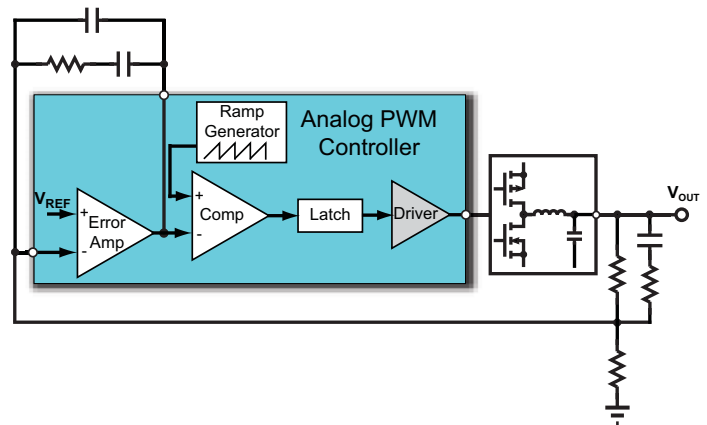

Figure 2.1 : Analog Feedback and Control Loop¹

Notes:
1. Figure 2.1 and 2.2 are copyrighted materials owned by Ericsson AB and its affiliates. They are reproduced by permission with the authorization and courtesy of Ericsson AB.

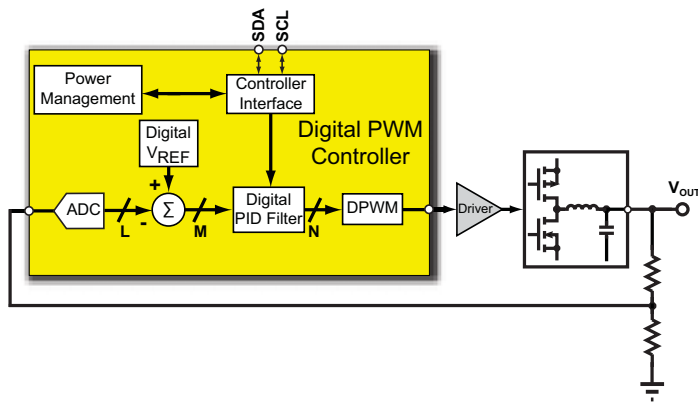

Figure 2.2 : Digital Feedback and Control Loop¹

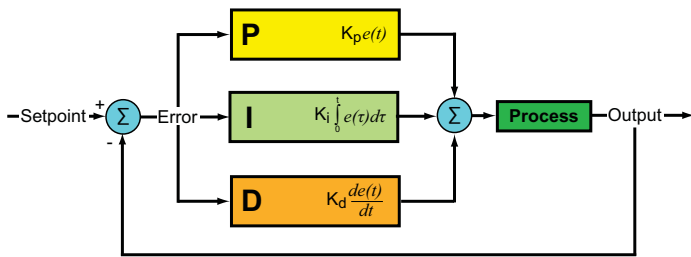

Figure 2.3 : Digital PID Filter

3.0 Benefits of Digital Power

Digital power ICs are providing benefits that were not previously achievable; moreover, the benefits will only keep improving as the technology matures. Some key benefits are described below:

1. Can Be Tested Under Real World Conditions Prior to Silicon

Prior to the start of IC design, systems engineers develop an FPGA (Field Programmable Gate Array) board which mimics the actual silicon. The FPGA board is used in an actual power supply system and the power supply performance and response to real world load conditions is measured. The algorithm and digital code is verified to produce the desired results and can be changed as necessary until the desired results are achieved. The digital code is then frozen and ported onto the silicon. This builds customer confidence and ensures that when the silicon comes out, it works right the first time and performs to real world conditions as expected. In the case of analog power ICs, the actual performance to real world conditions can not be evaluated until the silicon comes out. This often leads to multiple iterations of the silicon and increases the development time.

2. Able to Adjust Internal Parameters During Operation

An important benefit of digital power is its ability to adjust the internal parameters in response to varying line, load

and temperature conditions. For example, the efficiency curve can be made nearly flat from full load condition to low output current by switching between PWM to PFM (pulse frequency modulation) to DPWM (deep PWM) to DPFM (deep PFM) modes. In addition, the switching frequency can also vary in relation to the varying input line voltage to maximize efficiency over variation in line voltage. Moreover, standby or no-load power consumption can be significantly reduced by means of placing various sections of the IC in sleep-mode, similar to what is done with CPUs.

3. Can Provide Additional Methods to Reduce EMI

EMI, the bane of all power supply designers can also get a leg up from digital power. The best way for a power supply to reduce or eliminate EMI is not to generate it in the first place. Traditional techniques such as quasi-resonant switching and frequency jitter are commonly used in both digital and analog power supplies. A digital power IC can also control the turn-on slew rate of the power MOSFET in response to the output load thus further reducing EMI. Often, additional proprietary algorithms and control schemes are used to reduce EMI. The end result is that higher EMI margin can be achieved which results in lower EMI filtering cost and/or use of lower cost components.

4. Able to Eliminate Opto-Coupler

Digital primary feedback (called primary side regulation) makes it easier to eliminate opto-couplers in low to medium power isolated power supply applications while achieving tight $\pm 2\%$ output voltage and $\pm 3\%$ output current regulation for 3W to 5W handset wall chargers; and networking, PC tablet and game console adapters up to ~ 40 W. Although analog power ICs are available with primary side regulation at low power; at over 10W output power, analog power ICs require an opto-coupler and secondary side control circuit to match the tight voltage/current regulation performance of digital power supplies. Furthermore, eliminating an opto-coupler not only reduces cost but it also eliminates a weak link hence improving lifetime and reliability.

5. Improve Dimmer Detection for LED Lighting

Digital power is especially beneficial in the area of LED lighting. All the benefits described above can be employed. In addition, algorithm based digital LED drivers are best suited for detecting a myriad of dimmer types available worldwide and enabling the design of flicker-free dimmable lamps that allow seamless plug-and-play retrofit lamp replacement for incandescent bulbs.

Notes:

1. Figure 2.1 and 2.2 are copyrighted materials owned by Ericsson AB and its affiliates. They are reproduced by permission with the authorization and courtesy of Ericsson AB.

About iWatt

iWatt Inc. is a fabless semiconductor company that develops intelligent power management ICs for computer, communication, and consumer markets. The company's patented *pulse Train*[™] technology, the industry's first truly digital approach to power system regulation, is revolutionizing power supply design.

Trademark Information

© 2008 iWatt, Inc. All rights reserved. iWatt, *EZ-EMI* and *pulse Train* are trademarks of iWatt, Inc. All other trademarks and registered trademarks are the property of their respective companies.

Contact Information

Web: <http://www.iwatt.com>

E-mail: info@iwatt.com

Phone: 408-374-4200

Fax: 408-341-0455

iWatt Inc.

101 Albright Way

Los Gatos CA 95032-1827

Disclaimer

iWatt reserves the right to make changes to its products and to discontinue products without notice. The applications information, schematic diagrams, and other reference information included herein is provided as a design aid only and are therefore provided as-is. iWatt makes no warranties with respect to this information and disclaims any implied warranties of merchantability or non-infringement of third-party intellectual property rights.

Certain applications using semiconductor products may involve potential risks of death, personal injury, or severe property or environmental damage ("Critical Applications").

IWATT SEMICONDUCTOR PRODUCTS ARE NOT DESIGNED, INTENDED, AUTHORIZED, OR WARRANTED TO BE SUITABLE FOR USE IN LIFE-SUPPORT APPLICATIONS, DEVICES OR SYSTEMS, OR OTHER CRITICAL APPLICATIONS.

Inclusion of iWatt products in critical applications is understood to be fully at the risk of the customer. Questions concerning potential risk applications should be directed to iWatt, Inc.

iWatt semiconductors are typically used in power supplies in which high voltages are present during operation. High-voltage safety precautions should be observed in design and operation to minimize the chance of injury.